

CLUB GOAL ASSEMBLY

PARTS

1 Front Frame Assembly

This assembly forms the goal mouth. The front surface is smooth and has the ANTI brand in the centre of the crossbar. The rear surface has a groove all the way around, with enlarged openings at the corners where the crossbar joins the uprights. These openings allow the fixing blocks and eyelets to be correctly positioned. The feet of the assembly are closed with welded-on end caps.



6 Fixing Blocks

These blocks are provided with bolts attached. They are used for fixing the float assembly and the support bows to the front frame.

1 Float Assembly

This assembly is now supplied in completed form, except when transport costs are very high, and forms the base of the goal.

If your float assembly has been shipped unassembled, you will need to fit the square tube connecting the side floats with the bolts provided.



9 Eyelets

These are used to attach the canvas to the front frame, and are already attached to the canvas.

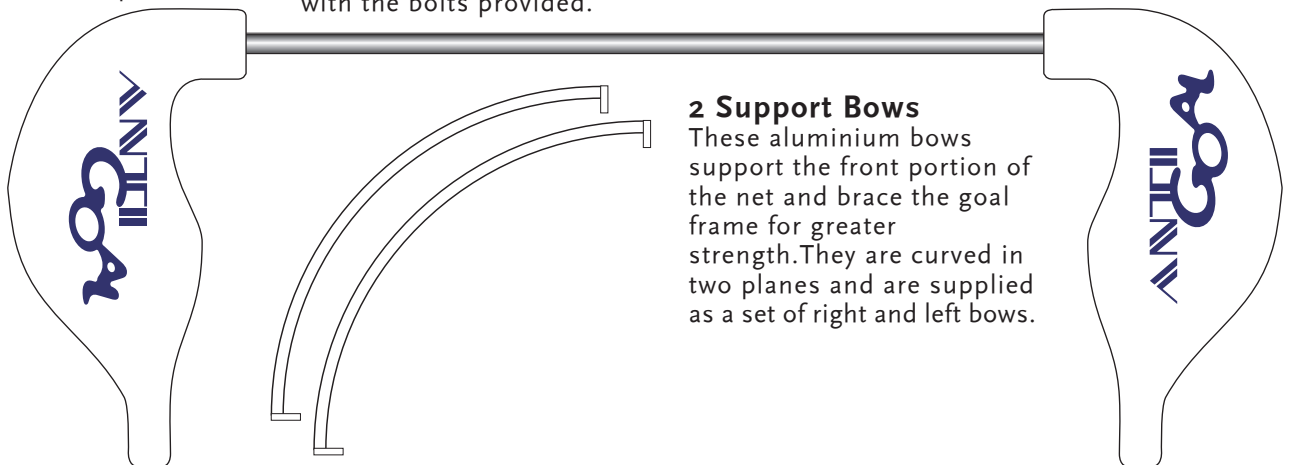

2 Support Bows

These aluminium bows support the front portion of the net and brace the goal frame for greater strength. They are curved in two planes and are supplied as a set of right and left bows.

1 Net

The canvas is made with a pocket along the bottom edge and has the eyelets already attached to it.

Fasteners

2 hex-head M10 bolts, 6 countersunk bolts, and sufficient washers and locknuts for these bolts and the fixing blocks are supplied with each goal.

Rope

Polyrope is supplied for lacing the net, and for the sidelines.

STEP 1

Mounting the Front Frame

Insert 1 Fixing Block through the enlarged opening in the slot and slide down to the base of each upright of the front frame. Note that the shaft of the bolt protrudes through the slot.

Place the front frame against the float assembly so that the base of each leg is located in the recess at the front of each side float. Push the front frame towards the goal assembly so that the bolt shaft passes through the opening in the fibreglass. attach the washer and locknut and tighten, but not completely.

Take a hex-head 10M bolt and thread into the hole in the base of each of the uprights. You will need the 16 mm wrench for this. Again tighten, but not fully.

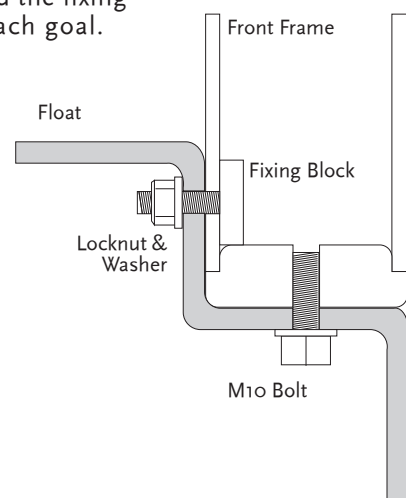

STEP 2

Eyelets

Fitting the eyelets to the front frame

Place 2 Eyelets on each side upright, Inserting them through the enlarged opening in the slot.

Place 5 Eyelets in the crossbar slot.

STEP 3

Fixing Blocks

Fitting the fixing blocks to the front frame

From each side, Insert one through the enlarged opening in the slot and position on the crossbar.

STEP 4

Fitting Support Bows to Float Assembly

Now the Support Bows are mounted on the float assembly.

Note that the bows are right and left.

Position the bow so that the three holes in the flange on one end line up with the boltholes in the float assembly and place the bolts through the flange.

Position the fixing block on the front frame so that the hole in the flange on the bow can be placed over it. Do not attach the nut and washer at this stage.

Attach washers and locknuts to the bolts passing through the bow flange, float assembly and back frame and tighten, but not completely.

STEP 5

Fitting the Net

Spacing eyelets, lacing net & hanging over bows

When you are facing the goal mouth, take the net and unfold it in front of you so that it is correctly oriented to the goal.

Space the eyelets evenly along the slot and lace the net through the eyelets on the front frame and the saddles fitted to the float assembly.

Hint

For best results knot the rope on each eyelet so that if the rope breaks with age and use, the knots will still stay. Cut the end of the rope with a sharp knife, and burn the ends of the polyrope to seal it. A cigarette lighter is the simplest and safest readily available tool for this job.

Take the top front edge of the net, and count 5 strands back. These last 5 meshes must be placed over the support bows so that the rest of the net falls freely from the bows.

Ease the front end of each bow away from the fixing block and place the last 5-mesh section of the net over it.

Place the front end of each bow back on its fixing block. Thread a length of rope through the net and the saddles fixed to the bows and secure.

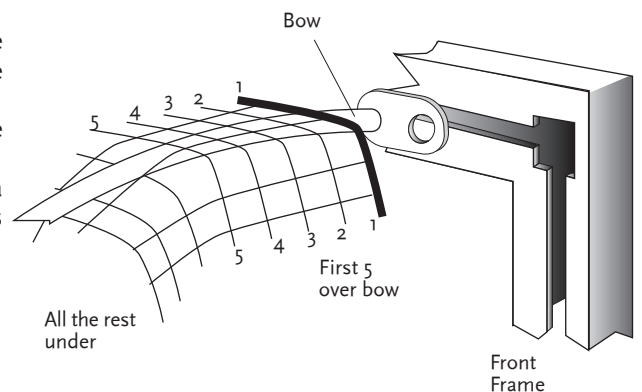

STEP 6

Fasten the Bows to the Front Frame

Now it is time to fasten the Support Bows to the front frame

Place a washer and locknut on the bolt shaft protruding from each fixing block through the flange on the front of each bow.

Tighten fully.

STEP 7

Final Tightening

Now it is time to tighten all nuts and bolts fully.

STEP 8

Placing the Goal in the Pool

Now the Goal is ready for floating.

The sidelines are attached to the anchor cables at the back of the goal and to the U-shaped saddles mounted towards the front of the side floats. Normal tension should be applied to these sidelines.

Generally, if polyrope is used, there will be little problem with overtensioning. If, however, you wish to use stainless steel cable with Anti Wave discs for sidelines, this should only be used on the rear sideline attached to the anchor cables. The front sidelines should only be polyrope. Excess tension should not be applied to any cable.

Note Anti Wave double anchor lines are available as an optional extra. These are strung with polyrope on the front lines and stainless steel cable on the rear lines and are fitted with Anti Wave discs.

FINA GOAL ASSEMBLY

PARTS

1 Front Frame Assembly

This assembly forms the goal mouth. The front surface is smooth and has the ANTI brand in the centre of the crossbar. The rear surface has a groove all the way around, with enlarged openings at the corners where the crossbar joins the uprights. These openings allow the fixing blocks and eyelets to be correctly positioned. The feet of the assembly are closed with welded-on end caps.

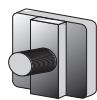

6 Fixing Blocks

These blocks are provided with bolts attached. They are used for fixing the float assembly and the support bows to the front frame.



9 Eyelets

These are used to attach the canvas to the front frame, and are already attached to the canvas.

1 Float Assembly

This assembly is now supplied in completed form and forms the base of the goal.

2 Support Bows

These aluminium bows support the front portion of the net and brace the goal frame for greater strength. They are curved in two planes and are supplied as a set of right and left bows.

1 Net

The canvas is made with a pocket along the bottom edge and has the eyelets already attached to it.

Fasteners

2 hex-head M10 bolts, 6 countersunk bolts, and sufficient washers and locknuts for these bolts and the fixing blocks are supplied with each goal.

Rope

Polyrope is supplied for lacing the net, and for the sidelines.

STEP 1

Mounting the Front Frame

Insert 1 Fixing Block through the enlarged opening in the slot and slide down to the base of each upright of the front frame. Note that the shaft of the bolt protrudes through the slot.

Place the front frame against the float assembly so that the base of each leg is located in the recess at the front of each side float. Push the front frame towards the goal assembly so that the bolt shaft passes through the opening in the fibreglass. attach the washer and locknut and tighten, but not completely.

Take a hex-head 10M bolt and thread into the hole in the base of each of the uprights. You will need the 16 mm wrench for this. Again tighten, but not fully.

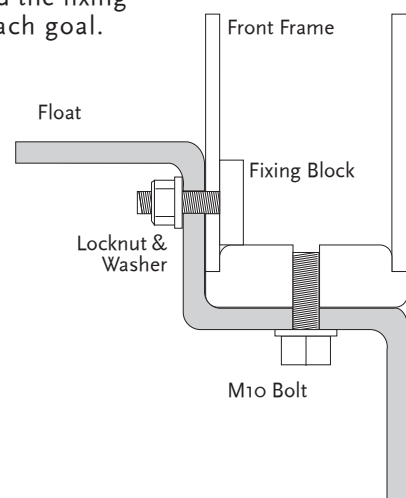

STEP 2

Eyelets

Fitting the eyelets to the front frame

Place 2 Eyelets on each side upright, Inserting them through the enlarged opening in the slot.

Place 5 Eyelets in the crossbar slot.

STEP 3

Fixing Blocks

Fitting the fixing blocks to the front frame

From each side, Insert one through the enlarged opening in the slot and position on the crossbar.

STEP 4

Fitting Support Bows to Float Assembly

Now the Support Bows are mounted on the float assembly.

Note that the bows are right and left.

Position the bow so that the three holes in the flange on one end line up with the boltholes in the float assembly and place the bolts through the flange.

Position the fixing block on the front frame so that the hole in the flange on the bow can be placed over it. Do not attach the nut and washer at this stage.

Attach washers and locknuts to the bolts passing through the bow flange, float assembly and back frame and tighten, but not completely.

STEP 5

Fitting the Net

Spacing eyelets, lacing net & hanging over bows

When you are facing the goal mouth, take the net and unfold it in front of you so that it is correctly oriented to the goal.

Space the eyelets evenly along the slot and lace the net through the eyelets on the front frame and the saddles fitted to the float assembly.

Hint

For best results knot the rope on each eyelet so that if the rope breaks with age and use, the knots will still stay. Cut the end of the rope with a sharp knife, and burn the ends of the polyrope to seal it. A cigarette lighter is the simplest and safest readily available tool for this job.

Take the top front edge of the net, and count 5 strands back. These last 5 meshes must be placed over the support bows so that the rest of the net falls freely from the bows.

Ease the front end of each bow away from the fixing block and place the last 5-mesh section of the net over it.

Place the front end of each bow back on its fixing block. Thread a length of rope through the net and the saddles fixed to the bows and secure.

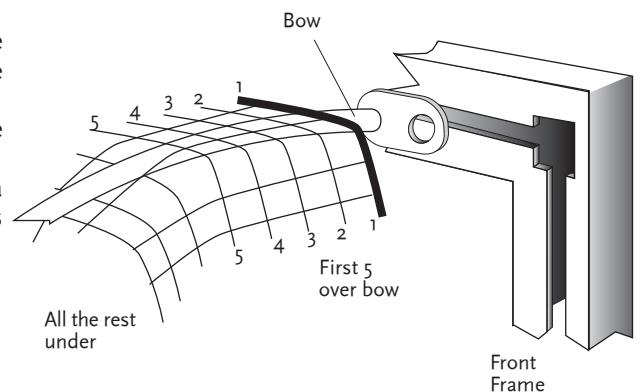

STEP 6

Fasten the Bows to the Front Frame

Now it is time to fasten the Support Bows to the front frame

Place a washer and locknut on the bolt shaft protruding from each fixing block through the flange on the front of each bow.

Tighten fully.

STEP 7

Final Tightening

Now it is time to tighten all nuts and bolts fully.

STEP 8

Placing the Goal in the Pool

Now the Goal is ready for floating.

The sidelines are attached to the anchor cables at the back of the goal and to the U-shaped saddles mounted towards the front of the side floats. Normal tension should be applied to these sidelines.

Generally, if polyrope is used, there will be little problem with overtensioning. If, however, you wish to use stainless steel cable with Anti Wave discs for sidelines, this should only be used on the rear sideline attached to the anchor cables. The front sidelines should only be polyrope. Excess tension should not be applied to any cable.

Note Anti Wave double anchor lines are available as an optional extra. These are strung with polyrope on the front lines and stainless steel cable on the rear lines and are fitted with Anti Wave discs.

WALL GOAL ASSEMBLY

PARTS

1 Front Frame Assembly

This assembly forms the goal mouth. The front surface is smooth and has the ANTI brand in the centre of the crossbar. The rear surface has a groove all the way around, with enlarged openings at the corners where the crossbar joins the uprights. These openings allow the fixing blocks and eyelets to be correctly positioned. The feet of the assembly are closed with welded-on end caps.



6 Fixing Blocks

These blocks are provided with bolts attached. They are used for fixing the water-level spacing bar and the support frames to the front frame.



9 Eyelets

These are used to attach the canvas to the front frame, and are already attached to the canvas.

1 Water-level Spacing Bar

This bar is connected to the front frame and holds the bottom of the canvas tight. The two extensions rest against the pool wall.

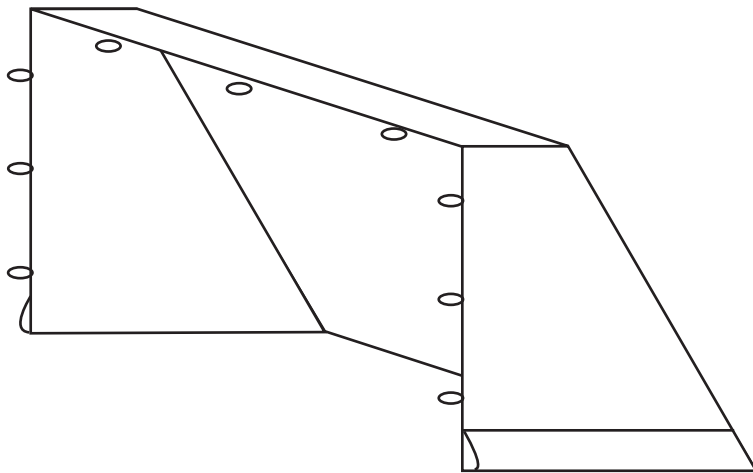

1 Canvas

The canvas is made with a pocket along the bottom edge and has the eyelets already attached to it.

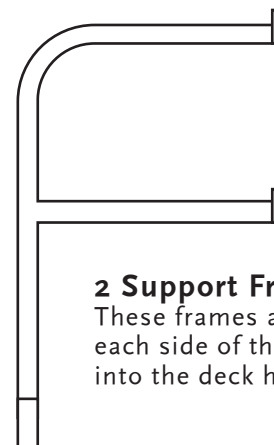

2 Support Frames

These frames are fitted on each side of the goal and fit into the deck holes.

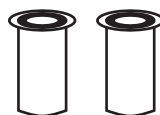

2 Deck Holes

These deck holes are located in the concourse or bulkhead top so that their centres are 114 mm from the water edge, 3032 mm apart, and in the centre of the end of the field of play.

ASSEMBLY & FITTING

Step 1 Deck Hole Installation

The deck holes should be installed before the goal is used. If the goal is being fitted to the concourse, see that the centres of the deck holes are located 114 mm from the waters edge and 3032 mm apart. Ideally you should wait one week after installation to use the goal. If the goal is to be used on a movable bulkhead, the bulkhead would normally be built with deckholes. If not, contact the manufacturer of your bulkhead before proceeding.

Note: The following procedures require two persons

Step 2 Fitting Canvas to top of Front Frame

First fit the top of the canvas to the front frame. Insert one of the attached eyelets through the enlarged opening at one end of the slot in the top bar of the front frame and slide it along the groove. Repeat with the other two eyelets until the top edge of the canvas is hanging from the front frame.

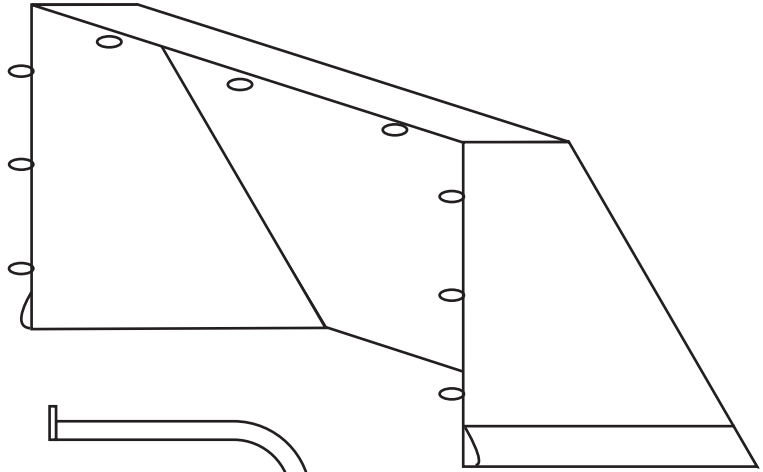

Step 3 Fit Sides of canvas & Support Frames

First, slide one fixing block through the enlarged opening at the top of the slot in one of the uprights of the front frame, and allow it to slide right to the bottom of the slot. Now, take the bottom eyelet on one side of the canvas and thread it through the opening and down the slot.

Next loosely attach a fixing block to each of the flanges on the support frame, and thread the fixing blocks through the opening and down the slot.

Finally thread the remaining eyelets through the opening and down the slot.

Repeat for the other side.

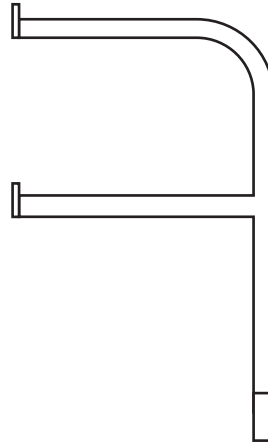

Step 4 Threading the Water-Level Spacing Bar

Next the water-level spacing bar is threaded through the pocket at the base of the canvas. Note that the extensions will protrude from the holes provided when the job is finished.

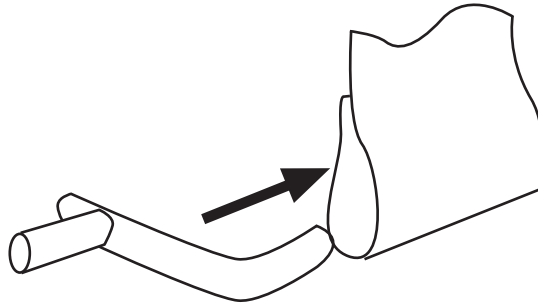

Step 5 Attaching the Water-Level Spacing Bar

When the spacing bar is threaded, attach the flange on each end to the fixing block at the bottom of each upright of the front frame and tighten the nuts.

Step 6 Final Fitting & Assembly

Take the whole assembly and locate in the deck holes. Move the front frame up or down on the support frames until the water level spacing bar is at water level. Tighten the nuts on the support frame flanges. The Goal is now ready for use.

Sales & Factory Unit 2-16 Maiella Street Stapylton 4207 • Tel 07 3807 77 44 • Fax 07 3807 5611
Head Office 65 Twelfth Avenue St Lucia 4067 • Tel 07 3371 6457 • Fax 07 3371 4169

DIVE INTO OUR WEBSITE AT www.anti.to