

Installation Instructions – Lane Anchor

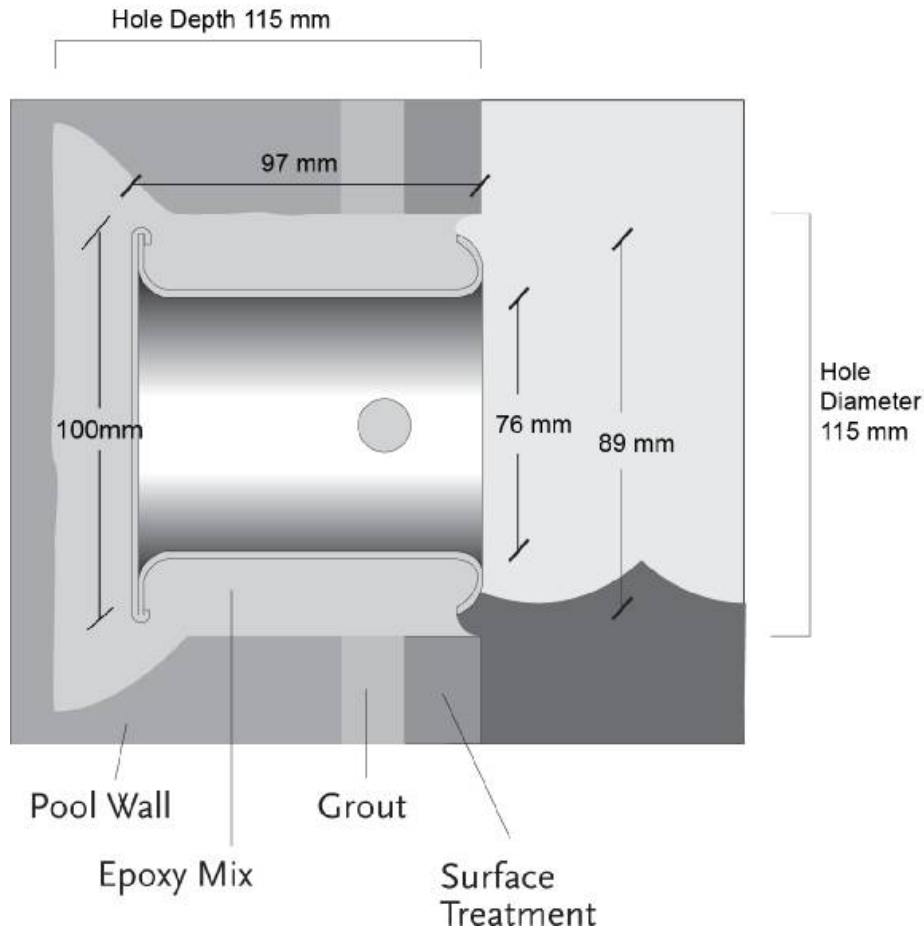

- Core drill hole to 15 mm wider than diameter of fitting and 15 mm deeper. For Lane Anchor this will be 115 mm diameter and 115 mm deep.
- Chisel out back of hole to wedge shaped profile using jack hammer drill
- Masking tape around hole to minimize mess
- Make up stiff mix of 2-part **vertical epoxy** (enough for 2 holes at a time). You may wish to add a little fine sand to the mix
- Coat generously the inside of the hole and back and outside of the anchor using more than you need.
- Push anchor in and turn to seat correctly. Re-use squeezed out mix.
- Clean up and allow 1 week to cure fully.
- Wait 24 hours before re-tiling and grouting around front/top flange

Installation Instructions – Deck Hole Anchor

For False Start/Backstroke Flag Set, Rails etc.

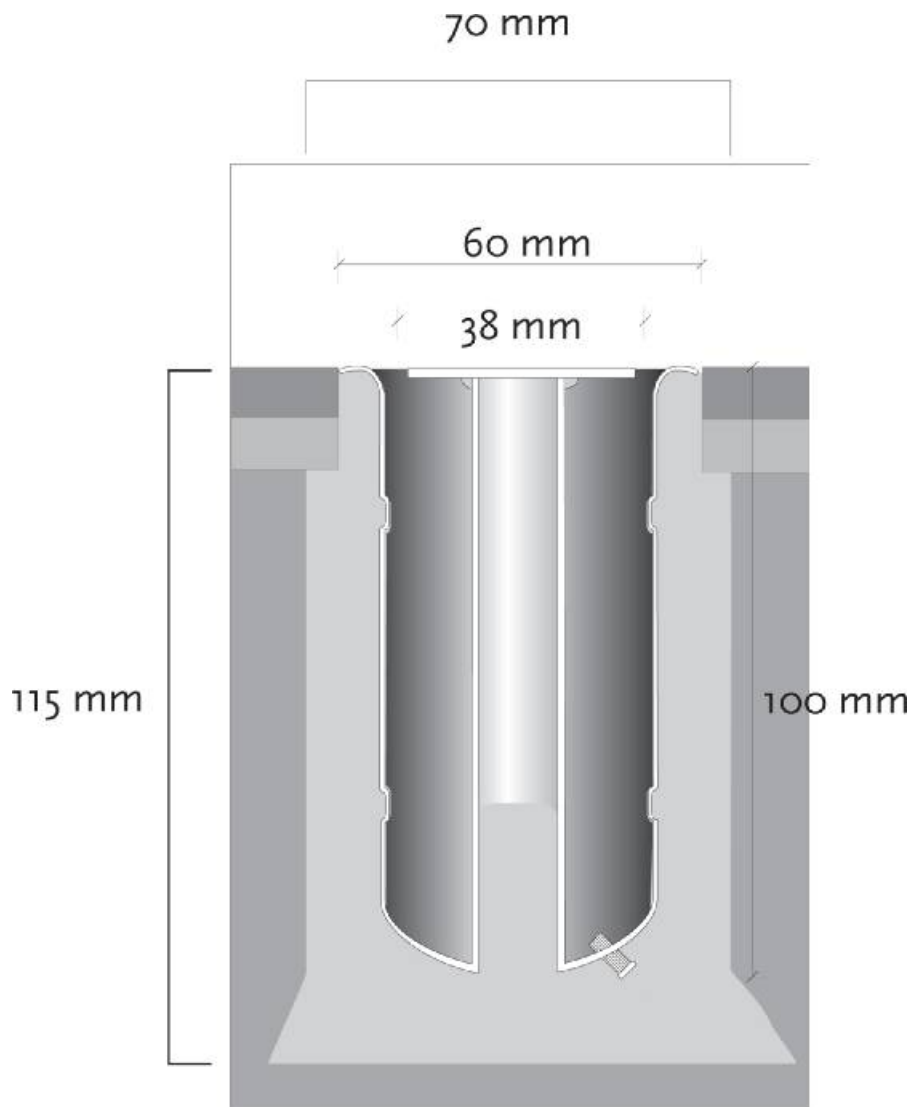

- Core drill hole to 10 mm wider than diameter of fitting and 15 mm deeper. For this anchor diameter is 70 mm and 115 mm deep.
- Chisel out back of hole to wedge shaped profile using jack hammer drill
- Masking tape around hole to minimize mess
- Use a 2-part gun grade epoxy and apply using gun (simplest method)
- Coat generously the inside of the hole and back of the anchor using more than you need.
- Push anchor in and turn to seat correctly.
- Clean up and allow 1 week to cure fully.
- Wait 24 hours before re-tiling and grouting around front/top flange